

Engine	Cummins 6LTAA9.3
Gross Power	162 kW (220 hp) @ 2,200 rpm
Net Power	148 kW (201 hp) @ 2,200 rpm
Operating Weight	17,000 kg
Standard Bucket Size	3 m <sup>3</sup>
Standard Breakout Force	160 kN
Standard Dump Clearance	3,100 mm

# 856 WHEEL LOADER



TOUGH WORLD. TOUGH EQUIPMENT.

# 856 SPECIFICATIONS >>>

## ENGINE

Emission Regulation	Tier 2 / Stage II
Make	Cummins
Model	6LTAA9.3
Gross Power	162 kW (220 hp) @ 2,200 rpm
Net Power	148 kW (201 hp) @ 2,200 rpm
Peak Torque	940 N · m
Displacement	9.3 L
Number of Cylinders	6
Aspiration	Turbocharged & Air-to-air intercooled

## TRANSMISSION

Transmission Type	Countershaft, power shift
Torque Converter	Single stage, three elements
Maximum Travel Speed, fwd	37 km/h
Maximum Travel Speed, rev	24 km/h
Number of Speeds, fwd	4
Number of Speeds, rev	3

## AXLES

Differential Front Type	Limited slip
Differential Rear Type	Limited slip
Axle Oscillation	±11°

## STEERING

Steering Configuration	Articulated
Steering Relief Pressure	16 MPa

## BRAKES

Service Brake Type	Wet discs brake
Service Brake Actuation	Hydraulic
Parking Brake Type	Manual electronic control
Parking Brake Actuation	Hydraulic

## HYDRAULIC SYSTEM

Main Pump Type	Gear
Main Relief Pressure	20 MPa
Raise	6 s
Dump Time	1.5 s
Float Down Time	3 s
Fastest Total Cycle Time	10.5 s

## LOADER ARM PERFORMANCE

Tipping Load - Straight	12,500 kg
Tipping Load - Full Turn	10,500 kg
Bucket Breakout Force	160 kN
Maximum Dump Angle at Full Height	45°
Dump Clearance at Full Height Discharge	3,100 mm
Dump Reach at Full Height Discharge	1,035 mm
Maximum Hinge Pin Height	4,154 mm
Maximum Digging Depth, Bucket Level	61 mm
Bucket Rollback at Ground Level	42°
Bucket Rollback at Carry	46°
Bucket Rollback at Maximum Height	59°

## BUCKET PERFORMANCE

Reference Bucket	3 m <sup>3</sup>
------------------	------------------

## DIMENSIONS

Length with Bucket Down	8,150 mm
Width Over Tires	2,750 mm
Wheelbase	3,250 mm
Wheel Tread	2,150 mm
Ground Clearance	431 mm
Turn Angle, Either Side	38°
Rear Angle of Departure	30°
Turning Radius, Outside of Tire	6,095 mm
Turning Radius, Center of Tire	5,795 mm
Turning Radius, Bucket Carry	6,775 mm

## TIRES

Tire Size	23.5 - 25
-----------	-----------

## OPERATING WEIGHTS

Operating Weight	17,000 kg
------------------	-----------

## SERVICE CAPACITY

Fuel Tank	320 L
Engine Oil	19 L
Cooling System	52 L
Hydraulic Reservoir	218 L
Transmission and Torque Converter	45 L
Axles, each	32 L

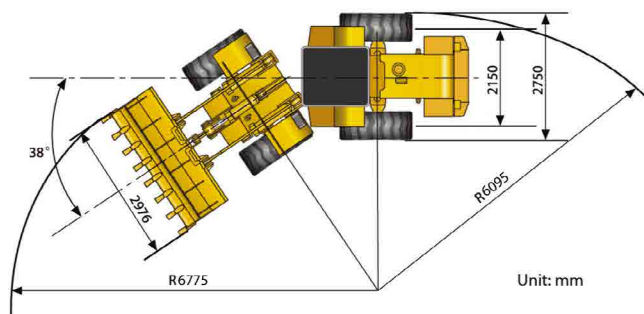
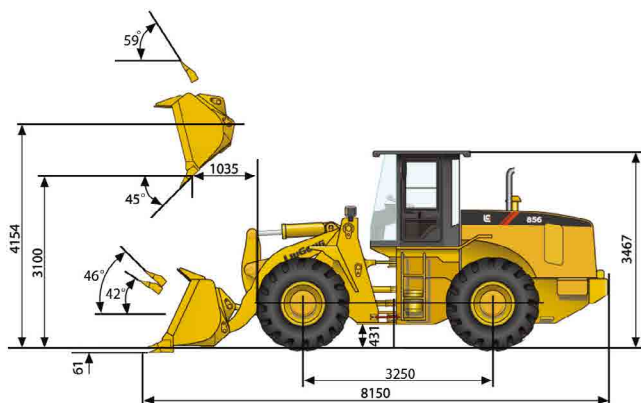

Guangxi Liugong Machinery Co., Ltd.

No. 1 Liutai Road, Liuzhou, Guangxi 545007, PR China  
 T: +86 772 3886124 E: overseas@liugong.com  
 www.liugong.com

Specifications and designs are subject to change without notice. Machines shown may include optional equipment.

05/2014 Designed by LiuGong