

Engine	Cummins 6LT9.3
Gross Power	162 kW (220 hp) @ 2,200 rpm
Net Power	148 kW (201 hp) @ 2,200 rpm
Operating Weight	17,000 kg
Standard Bucket Size	3 m ³
Standard Breakout Force	160 kN
Standard Dump Clearance	3,100 mm

856 WHEEL LOADER



TOUGH WORLD. TOUGH EQUIPMENT.

856 SPECIFICATIONS >>>

ENGINE

Emission Regulation	Tier 2 / Stage II
Make	Cummins
Model	6LT9.3
Gross Power	162 kW (220 hp) @ 2,200 rpm
Net Power	148 kW (201 hp) @ 2,200 rpm
Peak Torque	890 N · m
Displacement	9.3 L
Number of Cylinders	6
Aspiration	Turbocharged

TRANSMISSION

Transmission Type	Planetary type, Power shift
Torque Converter	Double stage, four elements
Maximum Travel Speed, fwd	38 km/h
Maximum Travel Speed, rev	16 km/h
Number of Speeds, fwd	2
Number of Speeds, rev	1

AXLES

Differential Front Type	Conventional
Differential Rear Type	Conventional
Axle Oscillation	±11°

STEERING

Steering Configuration	Articulated
Steering Relief Pressure	16 MPa

BRAKES

Service Brake Type	Caliper disc brake
Service Brake Actuation	Air over hydraulic
Parking Brake Type	Manual pneumatic control
Parking Brake Actuation	Air

HYDRAULIC SYSTEM

Main Pump Type	Gear
Main Relief Pressure	20 MPa
Raise	6 s
Dump Time	1.5 s
Float Down Time	3 s
Fastest Total Cycle Time	10.5 s

LOADER ARM PERFORMANCE

Tipping Load - Straight	12,500 kg
Tipping Load - Full Turn	10,500 kg
Bucket Breakout Force	160 kN
Maximum Dump Angle at Full Height	45°
Dump Clearance at Full Height Discharge	3,100 mm
Dump Reach at Full Height Discharge	1,035 mm
Maximum Hinge Pin Height	4,154 mm
Maximum Digging Depth, Bucket Level	61 mm
Bucket Rollback at Ground Level	42°
Bucket Rollback at Carry	46°
Bucket Rollback at Maximum Height	59°

BUCKET PERFORMANCE

Reference Bucket	3 m ³
------------------	------------------

DIMENSIONS

Length with Bucket Down	8,150 mm
Width Over Tires	2,750 mm
Wheelbase	3,315 mm
Wheel Tread	2,150 mm
Ground Clearance	431 mm
Turn Angle, Either Side	38°
Rear Angle of Departure	30°
Turning Radius, Outside of Tire	6,095 mm
Turning Radius, Center of Tire	5,795 mm
Turning Radius, Bucket Carry	6,775 mm

TIRES

Tire Size	23.5 - 25
-----------	-----------

OPERATING WEIGHTS

Operating Weight	17,000 kg
------------------	-----------

SERVICE CAPACITY

Fuel Tank	320 L
Engine Oil	19 L
Cooling System	58 L
Hydraulic Reservoir	210 L
Transmission and Torque Converter	45 L
Axles, each	32 L

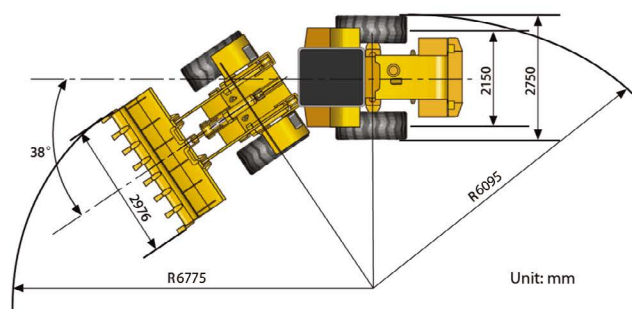
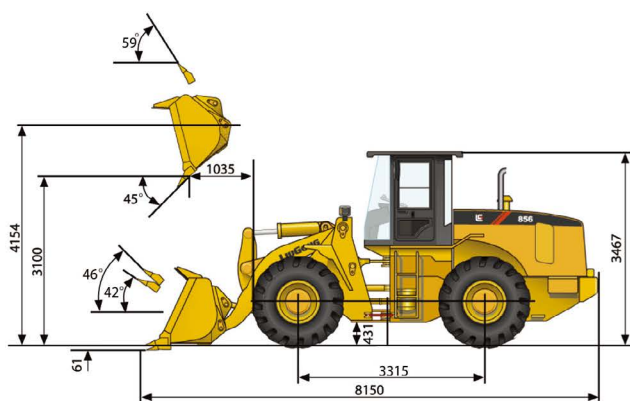

Guangxi Liugong Machinery Co., Ltd.

No. 1 Liutai Road, Liuzhou, Guangxi 545007, PR China
T: +86 772 3886124 E: overseas@liugong.com
www.liugong.com

Specifications and designs are subject to change without notice. Machines shown may include optional equipment.

05/2014 Designed by LiuGong